

DIN-I-420TR: 4... 20mA loop isolator.

- 4..20mA loops galvanic isolation.
- No additional power supply needed.
- Isolation for loop powered transmitters.
- PLC's output isolation.
- Extreme connection simplicity.
- Service and 5 years guarantee.

GENERAL DESCRIPTION

The DIN-I-420TR module generates in its output a 4..20mA current loop identical to the one present in its input but isolated galvanically to this one.

Unlike the DIN-I-420 device, the DIN-I-420TR output is a active current loop whose energy comes from the input loop.

In addition allows to isolate current loops coming from sensors fed by 4..20mA loop (2 wire with passive 4..20mA output loop).

Its installation is extremely simple, it is just inserted in an operative 4..20mA loop. No wiring or additional equipment is needed.

Common applications are to create safe barriers and floating ground references for interconnecting several equipment without creating current return conflicts.

Galvanic isolation eliminates the problems produced by ground potential differences in the plant and reduces the ones produced by electromagnetic interference.

TECNICAL SPECIFICATIONS

INPUT:

Current min.:	2 mA
Current max.:	22 mA
Current (short circuited output):	80 mA max.
Voltage drop:	3.0 V max.

OUTPUT:

Load resistans.	800 ohms max
Transmission error	0.1 % max
Load change error	0.03 % max. by each 100 ohms load change
Temperature stability:	25 ppm / °C max.

GENERAL:

Chopper freccuency.	15 kHz aprox.
Isolation:	4000 V min.

CONSTRUCTION:

Material:	Poliester; IP65
Total dimensions:	22 mm wide, 75 mm heigth , 110 mm deep.
Assembly	Rail DIN
Weight:	100 grams.
Operation temperature:	-10 ... 50 °C.

CONNETIONS AND INTERNAL DIAGRAM

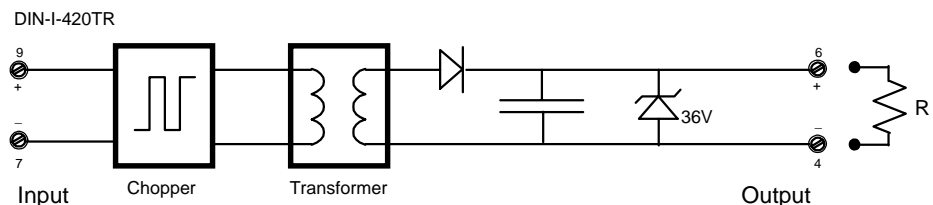

OPERATION

The DIN-I-420TR isolator is what sometimes is called DC transformer. It's composed by a oscillator (chopper) that converts input current in square pulses that pass through a current transformer with 1/1 relation. In the secondary side of the transformer pulses are rectified and filtered to obtain the output current loop. The zener diode is only for protection.

The circuit reproduces in the output the same current present in the input, except by a 3V drop required to feed chopper and to replace the drop in secondary diodes.

Also it is possible to operate the circuit in inverse form taking advantage that the transformer reflects in the primary side the current present in the secondary side.

The example #2 presented ahead operates under this principle for feeding with current a fed by loop sensor (2 wires with passive 4..20 mA output).

APPLICATIONS

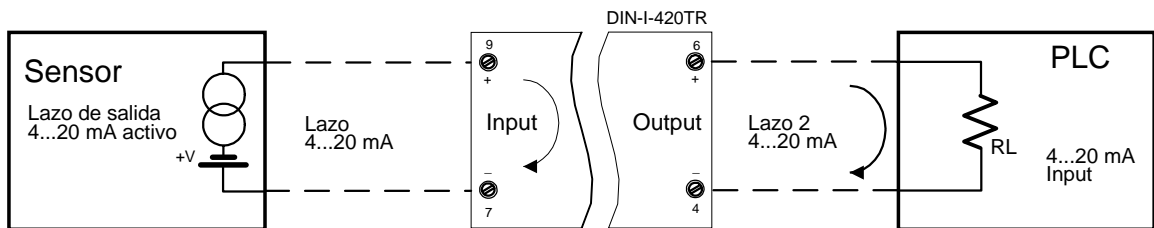
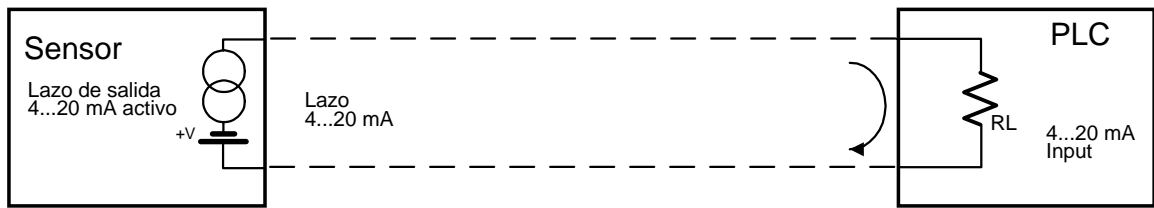

Example 1: Galvanical isolation of PLC input connected to an active 4..20mA current loop.

UP: The PLC receives in its input an active 4..20 mA current loop from a sensor.

DOWN: The DIN-I-420TR is installed to isolate the sensor from the PLC. The isolator generates in its output an active 4..20mA loop identical to the one in its input.

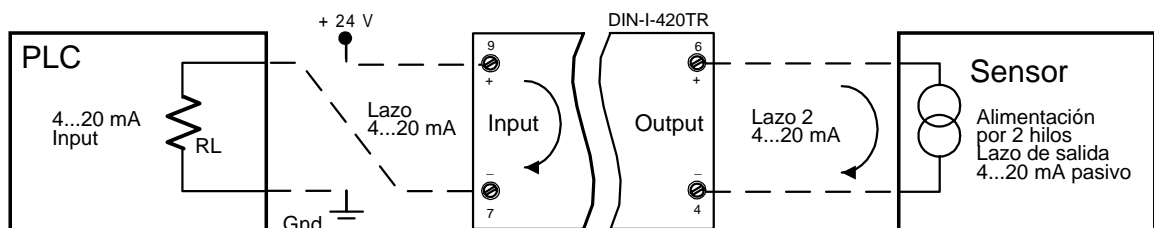
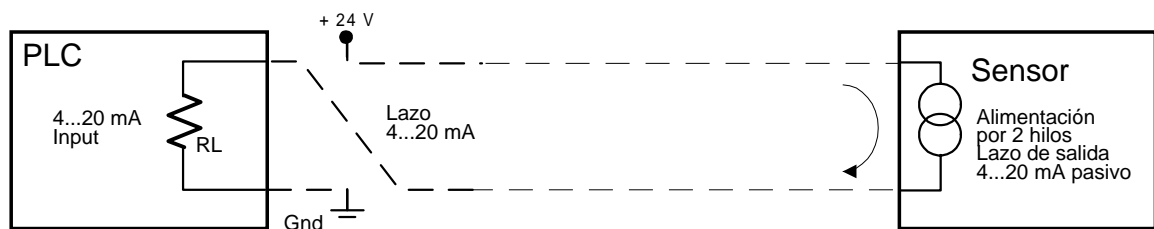

Example 2: PLC 4..20 mA input isolation connected to a loop fed sensor.

UP: The PLC receives by its input a 4..20mA signal that comes from a sensor fed by the same 4..20mA loop. (is a 2 wire sensor with passive 4..20mA output)

DOWN: The DIN-I-420TR is connected to isolate the sensor from the PLC and simultaneously source current to the sensor.

In this case the insulator works by the current reflected in its primary side when varying load in the secondary one.

The sensor has an output current regulator (2 circles symbol) that modulates current in loop 2 and this current is identically reflected in the input loop of the isolator and thus also in the PLC input. (note that apparently the insulator is connected reversed)

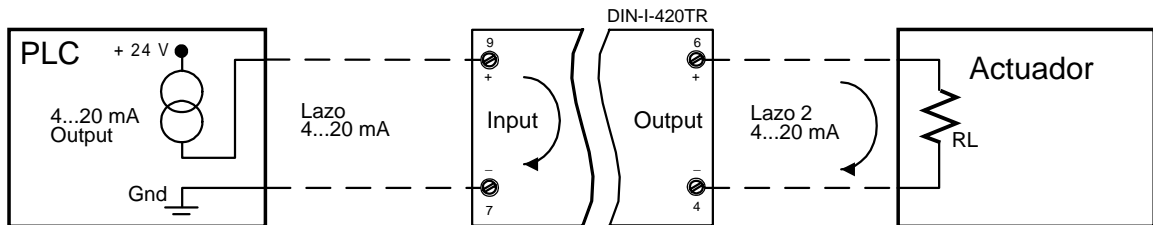
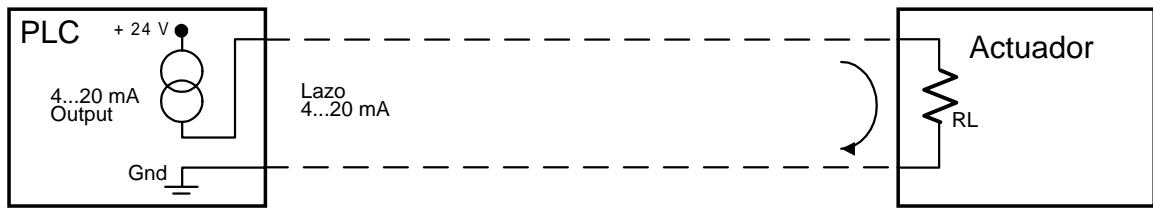

Example 3: Galvanical isolation of a PLC 4..20mA output.

UP: The PLC output is connected to an actuator (for ex. a variable speed AC motor driver). The PLC output sources a current that goes through the input resistance load of the actuator (RL).

UP: It's shown the same loop with a DIN-I-420TR inserted.

Ejemplo 4: Two common ground instruments 4..20 mA input

Two instruments, a controller and a monitor need to have 4... 20mA input from the same sensor and simultaneously to have common grounds.

The problem appears with the common ground requirement, because it is impossible to make a 4...20mA loop series connection through both instruments.

The solution is to generate a second identical but isolated current loop with floating ground for the monitor instrument.

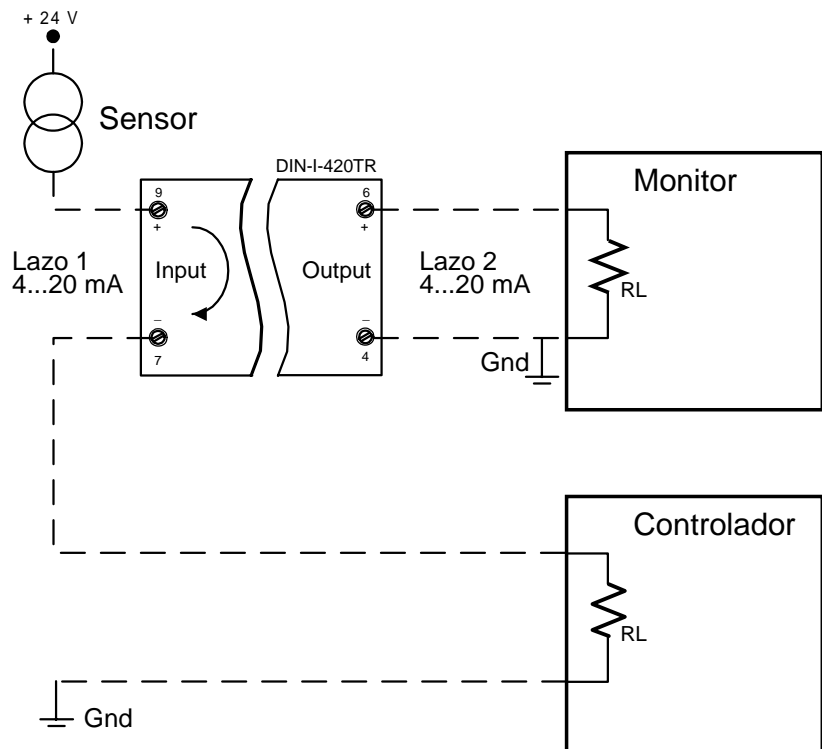

PART CODE:

DIN-I-420TR

FOR MORE INFORMATION:

ARIAN S. A.

Teniente Montt 1932, Nuñoa,
Santiago, Chile
Fone/Fax 56-2-4249363
arian@arian.cl
www.arian.cl